

CM-606-96

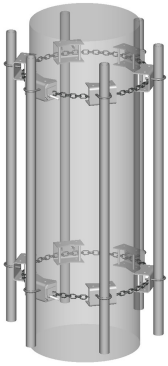

Chain Mount Kit, 16 ft chain, includes pipe

Product Classification

Product Type Chain mount kit

General Specifications

Chains, quantity 2

Pipe, quantity 6

Sectors, quantity 6

Dimensions

Height 152.4 mm | 6 in

Width 203.2 mm | 8 in

Length 2,438.4 mm | 96 in

Chain Length 4,902.2 mm | 193 in

Pipe Length 2,438.4 mm | 96 in

Mounting Diameter, maximum 1524 mm | 60 in

Mounting Diameter, minimum 355.6 mm | 14 in

Pipe Outer Diameter 60.96 mm | 2.4 in

Mounting Circumference, maximum 4,775.2 mm | 188 in

Mounting Circumference, minimum 1,117.6 mm | 44 in

CM-606-96

Outline Drawing

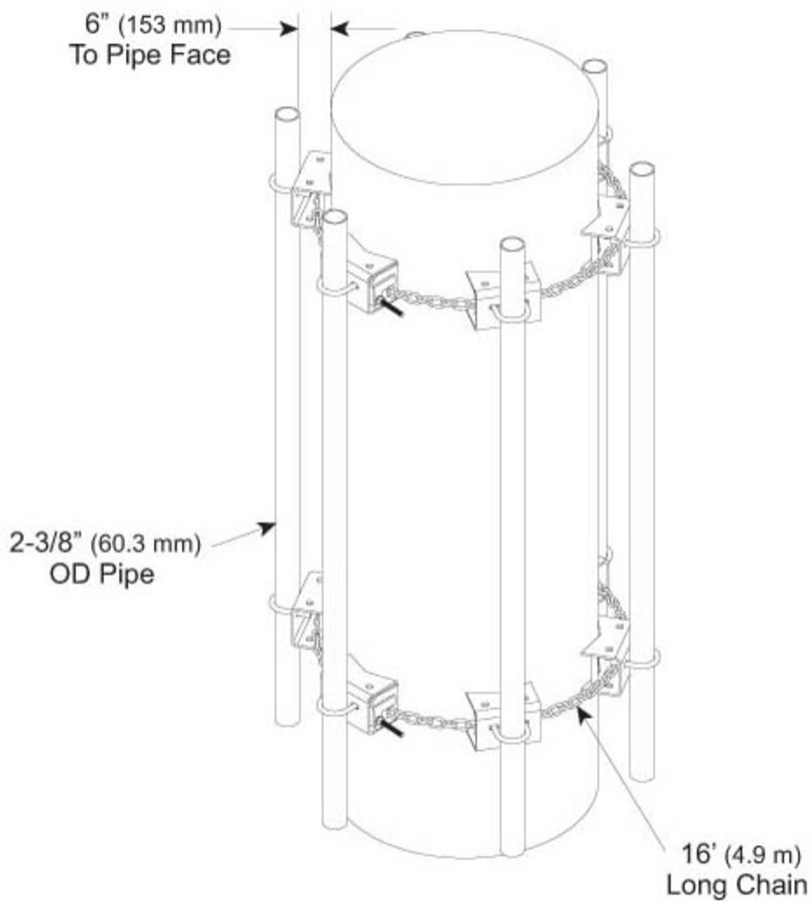

Material Specifications

Material Type Hot dip galvanized steel

Mechanical Specifications

Wind Rating 120 mph (BWS) at 100 ft AGL

Wind Rating Criteria One 96 in x 10 in panel antenna per sector

Wind Rating Test Method TIA/EIA-222

Packaging and Weights

Included Chains | Plain end pipes

CM-606-96

Packaging quantity 1
Weight, net 124.7 kg | 274.916 lb

Regulatory Compliance/Certifications

Agency	Classification
ISO 9001:2015	Designed, manufactured and/or distributed under this quality management system

Included Products

- CM-606-B - Chain Mount Base Kit, 14 in stand-off 16 ft chain
- MT-651-96 - Plain End Pipe, 2-3/8 in OD x 96 in .120" A500C 46Ksi

* Footnotes

Wind Rating BWS—Base Wind Speed; FBC—Florida Building Code